

Heavy Duty Shock Absorbers



ITT

ENGINEERED FOR LIFE

HEAVY DUTY SHOCK ABSORBERS



Applications:

- Amusement ride emergency stops
- Transportation safety stops
- Ladle transfer cars
- Coil upenders/downenders
- Rolling mill chock separators
- Furnace slab bumpers
- Hot strip mill down-coiler
- Re-heat furnace entry end shock absorber
- Gantry/Stacker Cranes



Table of Contents

Product Selection

Company Overview	1
New Technologies and Enhancements	2
Theory of Energy Absorption	3
Sizing Examples	4-6

Energy Absorption Products

HDN/HDA Series (Heavy Duty Shock Absorbers)	
Overview	7
Technical Data	8-14
Adjustment Techniques	13-14
HD Series (Heavy Duty Shock Absorbers)	
Overview	15
Technical Data	16-17
Mounting and Accessories	18-19
Ordering Information	19
Application Worksheet	20

ITT Enidine Inc., a preferred source for energy absorption and vibration isolation solutions, offers a full range of Heavy Duty (HDN/HDA/HD) products, each designed to protect equipment from large impacts in applications where consistent deceleration and safety is required.

Need Assistance? ITT Enidine Inc. is ready to answer your questions, feel free to contact us at:

Phone: Toll Free - 1.800.852.8508
Direct - 1.716.662.1900

Fax: General - 1.716.662.1909
Industrial - 1.716.662.0406

Email: industrialsales@enidine.com

Online: www.enidine.com





ITT is a diversified leading manufacturer of highly engineered critical components and customized technology solutions for growing industrial end-markets in energy infrastructure, electronics, aerospace and transportation. Building on its heritage of innovation, ITT partners with its customers to deliver enduring solutions to the key industries that underpin our modern way of life. Founded in 1920, ITT is headquartered in White Plains, NY, with employees in more than fifteen countries and sales in more than 125 countries. The company generated pro forma 2010 revenues of approximately \$2 billion. For more information, visit www.itt.com.

“ITT Enidine Inc. is widely recognized as the preferred source for energy absorption and vibration isolation products.”

From Original Equipment Manufacturers (OEM) to aftermarket applications, ITT Enidine Inc. offers a unique combination of product selection, engineering excellence and technical support to meet even the toughest energy absorption application requirements.

Global Manufacturing and Sales Facilities offer our customers:

- ***Highly Trained Distribution Network***
- ***State-of-the Art Engineering Capabilities***
- ***Custom Solution Development***
- ***Customer Service Specialists***
- ***Multiple Open Communication Channels***

If you are unsure whether one of our standard products meets your requirements, feel free to speak with one of our technical representatives **toll-free at 1-800-852-8508**, or contact us via **e-mail at techsales@enidine.com**.

Products/Engineering/Technical Support

ITT Enidine Inc. continually strives to provide the widest selection of shock absorbers and rate control products in the global marketplace. Through constant evaluation and testing, we bring our customers the most cost effective products with more features, greater performance and improved ease of use.

New Technologies and Enhancements

Research and Development

ITT Enidine Inc. engineers continue to monitor and influence trends in the motion control industry, allowing us to remain at the forefront of new energy absorption and vibration isolation product development.

Our experienced engineering team has designed custom solutions for a wide variety of challenging applications, including automated warehousing systems and shock absorbers for hostile industrial environments such as glass manufacturing, among others. These custom application solutions have proven to be critical to our customers' success. Let ITT Enidine Inc. engineers do the same for you.



Custom designs are not an exception at ITT Enidine Inc., they are an integral part of our business. Should your requirements fit outside of our standard product range, ITT Enidine Inc. engineers can assist in developing special finishes, components, hybrid technologies and new designs to ensure a "best-fit" product solution customized to your exact specifications.

Global Service and Support

ITT Enidine Inc. offers its customers a global network of customer service staff technical sales personnel that are available to assist you with all of your application needs.

- Operating with lean manufacturing and cellular production, ITT Enidine Inc. produces higher quality custom and standard products with greater efficiency and within shorter lead times.
- An authorized Global Distribution Network is trained regularly by ITT ENIDINE Inc. staff on new products and services ensuring they are better able to serve you.
- Global operations in United States, Germany, China, and Japan.
- A comprehensive, website full of application information, technical data, sizing examples and information to assist in selecting the product that's right for you.

Our website also features a searchable worldwide distributor lookup to help facilitate fast, localized service. Contact us today for assistance with all of your application needs.

New Products and Services

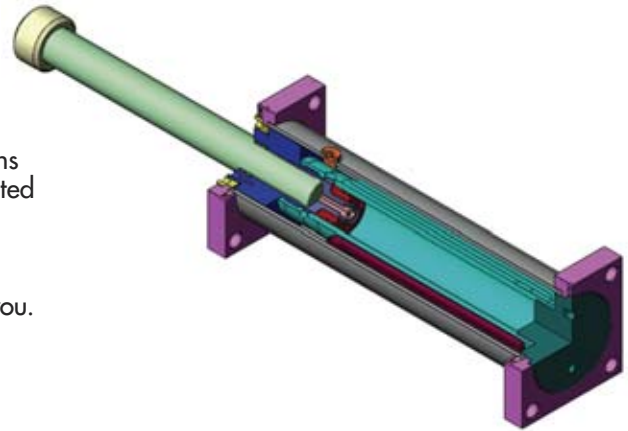

A talented engineering staff works to design and maintain the most efficient energy absorption product lines available today, using the latest engineering tools:

- **Solid Modeling**
- **3-D CAD Drawings**
- **3-D Soluble Support Technology**
- **Finite Element Analysis**
- **Complete Product Verification Testing Facility**

New product designs get to market fast because they can be fully developed in virtual environments before a prototype is ever built. This saves time and lets us optimize the best solution using real performance criteria.



Our global customer service and technical sales departments are available to assist you find the solution that's right for your application needs. Call us at 1.800.852.8508 or e-mail us at industrialsales@enidine.com and let us get started today.

As companies strive to increase productivity by operating machinery at higher speeds, often the results are increased noise, damage to machinery/products, and excessive vibration. At the same time, safety and machine reliability are decreased. A variety of products are commonly used to solve these problems. However, they vary greatly in effectiveness and operation. Typical products used include rubber bumpers, springs, cylinder cushions and shock absorbers. The following illustrations compare how the most common products perform:

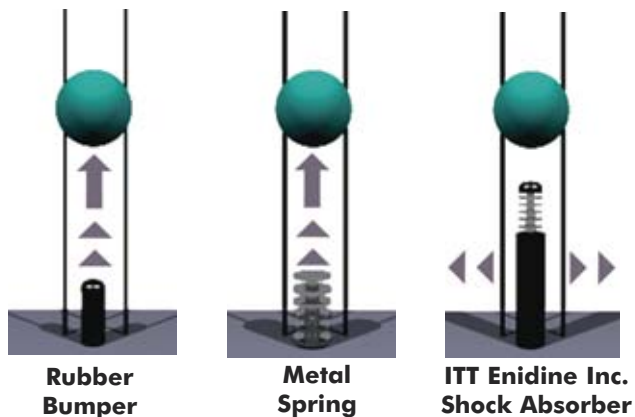

All moving objects possess kinetic energy. The amount of energy is dependent upon weight and velocity. A mechanical device that produces forces diametrically opposed to the direction of motion must be used to bring a moving object to rest.

Rubber bumpers and springs, although very inexpensive, have an undesirable recoil effect. Most of the energy absorbed by these at impact is actually stored. This stored energy is returned to the load, producing rebound and the potential for damage to the load or machinery. Rubber bumpers and springs initially provide low resisting force which increases with the stroke.

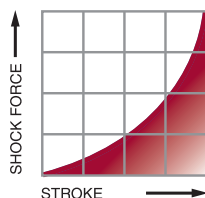

Cylinder cushions are limited in their range of operation. Most often they are not capable of absorbing energy generated by the system. By design, cushions have a relatively short stroke and operate at low pressures resulting in very low energy absorption. The remaining energy is transferred to the system, causing shock loading and vibration.

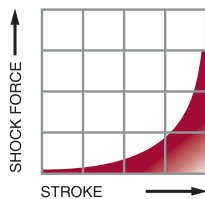

Shock absorbers provide controlled, predictable deceleration. These products work by converting kinetic energy to thermal energy. More specifically, motion applied to the piston of a hydraulic shock absorber pressurizes the fluid and forces it to flow through restricting orifices, causing the fluid to heat rapidly. The thermal energy is then transferred to the cylinder body and harmlessly dissipated to the atmosphere.

Shock Absorber Performance When Weight or Impact Velocity Vary

When conditions change from the original calculated data or actual input, a shock absorber's performance can be greatly affected, causing failure or degradation of performance. Variations in input conditions after a shock absorber has been installed can cause internal damage, or at the very least, can result in unwanted damping performance. Variations in weight or impact velocity can be seen by examining the following energy curves:

Varying Impact Weight: Increasing the impact weight (impact velocity remains unchanged), without reorificing or readjustment will result in increased damping force at the end of the stroke. Figure 1 depicts this undesirable bottoming peak force. This force is then transferred to the mounting structure and impacting load.

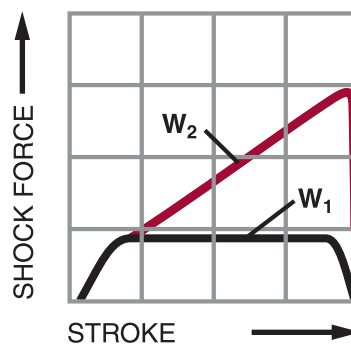

Figure 1

Varying Impact Velocity: Increasing impact velocity (weight remains the same) results in a radical change in the resultant shock force. Shock absorbers are velocity conscious products; therefore, the critical relationship to impact velocity must be carefully monitored. Figure 2 depicts the substantial change in shock force that occurs when the velocity is increased. Variations from original design data or errors in original data may cause damage to mounting structures and systems, or result in shock absorber failure if the shock force limits are exceeded.

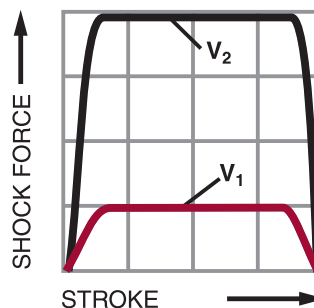

Figure 2

Shock Absorber Sizing Examples

Typical Shock Absorber and Stacker Crane Application

Overview

Shock Absorber Sizing Examples

Application 1	Value
Buffer Distance H	ft.
Distance X ₁	ft.
Distance Y ₁	ft.
Distance X ₂	ft.
Distance Y ₂	ft.
Total Weight	lbs.
W _{max d}	lbs.
W _{min d}	lbs.
W _{max u}	lbs.
W _{min u}	lbs.

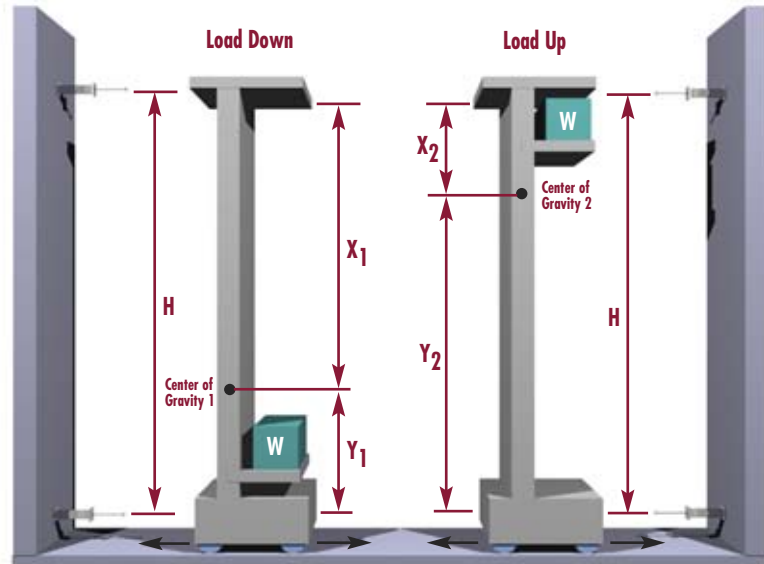

Calculation Example Stacker Cranes

Please note that this example shows how to calculate the maximum impact weight on the upper and lower shock absorbers for a stacker crane.

Distance Between Buffers:	H = 60 ft.
Distance to C of G1 - Upper:	X ₁ = 45 ft.
Distance to C of G1 - Lower:	Y ₁ = 15 ft.
Distance to C of G2 - Upper:	X ₂ = 21 ft.
Distance to C of G1 - Lower:	Y ₂ = 39 ft.
Total Weight:	W = 40,000 lbs.
$W_{\max d} = \frac{X_1}{H} \cdot W$	$W_{\max d} = \frac{X_2}{H} \cdot W$
$W_{\max d} = \frac{15 \text{ m}}{20 \text{ m}} \cdot 20 \text{ t}$	$W_{\max d} = \frac{21 \text{ ft.}}{60 \text{ ft.}} \cdot 40,000 \text{ lbs.}$
$W_{\max d} = 15 \text{ t}$	$W_{\max d} = 14,000 \text{ lbs.}$
$W_{\max d} = \frac{Y_1}{H} \cdot W$	$W_{\max d} = \frac{Y_2}{H} \cdot W$
$W_{\max d} = \frac{5 \text{ m}}{20 \text{ m}} \cdot 20 \text{ t}$	$W_{\max d} = \frac{39 \text{ ft.}}{60 \text{ ft.}} \cdot 40,000 \text{ lbs.}$
$W_{\max d} = 5 \text{ t}$	$W_{\max d} = 26,000 \text{ lbs.}$
Using the value for W _{max} obtained above, the kinetic energy can be calculated, and a shock absorber selected.	

Given Values

Calculation
for Lower
Shock Absorbers

Calculation
for Upper
Shock Absorbers

Shock Absorber
Selection

Shock Absorber Sizing Examples

Typical Shock Absorber and Crane Applications

Overview

Calculations assume worst case scenario of 90% trolley weight over one rail.

Crane A		Per Buffer
Propelling Force Crane	lbs.	
Propelling Force Trolley	lbs.	
Weight of Crane (W_a)	lbs.	
Weight of Trolley (W_{ta})	lbs.	
Crane Velocity (V_a)	in./sec.	
Trolley Velocity (V_{ta})	in./sec.	

Crane B		Per Buffer
Propelling Force Crane	lbs.	
Propelling Force Trolley	lbs.	
Weight of Crane (W_b)	lbs.	
Weight of Trolley (W_{tb})	lbs.	
Crane Velocity (V_b)	in./sec.	
Trolley Velocity (V_{tb})	in./sec.	

Crane C		Per Buffer
Propelling Force Crane	lbs.	
Propelling Force Trolley	lbs.	
Weight of Crane (W_c)	lbs.	
Weight of Trolley (W_{tc})	lbs.	
Crane Velocity (V_c)	in./sec.	
Trolley Velocity (V_{tc})	in./sec.	

Please note:

Unless instructed otherwise, ITT Enidine Inc. will always calculate with:

- 100% velocity v , and
- 100% propelling force F_D

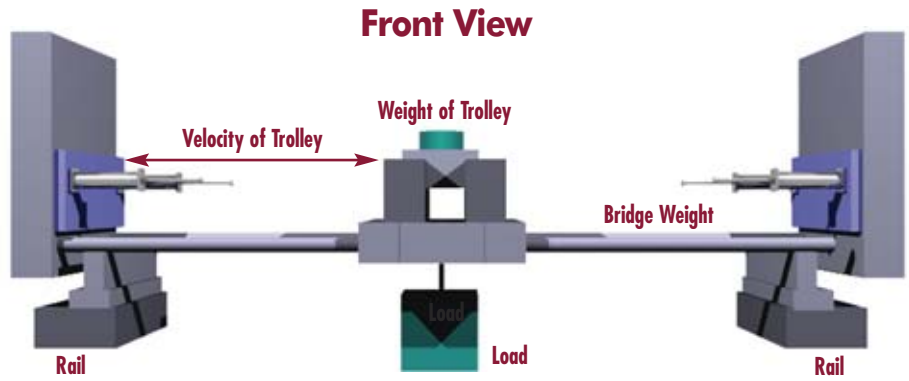

Plan Views

Application 1

Crane A against Solid Stop

Velocity:

$$V_r = V_a$$

Impact weight per buffer:

$$W_d = \frac{W_a + (1.8) W_{ta}}{\text{Total Number of Shocks}}$$

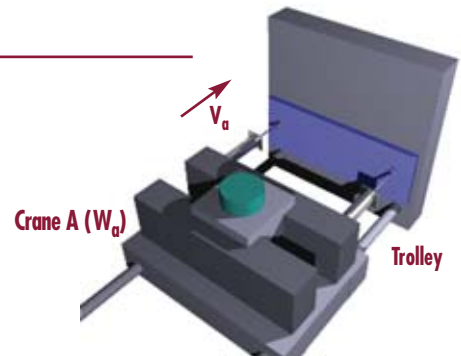

Application 2

Crane A against Crane B

Velocity:

$$V_r = V_a + V_b$$

Impact weight per buffer:

$$W_1 = W_a + (1.8) W_{ta}$$

$$W_2 = W_b + (1.8) W_{tb}$$

$$W_d = \frac{W_1 W_2}{(W_1 + W_2)(\text{Total Number of Shocks})}$$

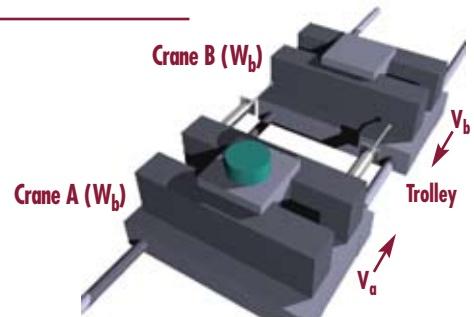

Application 3

Crane B against Crane C

Velocity:

$$V_r = \frac{V_b + V_c}{2}$$

Impact weight per buffer:

$$W_1 = W_b + (1.8) W_{tb}$$

$$W_2 = W_c + (1.8) W_{tc}$$

$$W_d = \frac{2 W_1 W_2}{(W_1 + W_2)(\text{Number of Shocks Per Rail})}$$

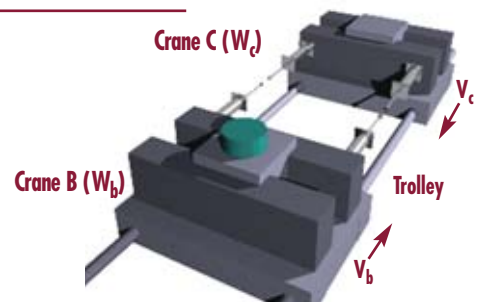

Application 4

Crane C against Solid Stop with Buffer

Velocity:

$$V_r = \frac{V_c}{2}$$

Impact weight per buffer:

$$W_1 = W_c + 1.8 (W_{tc})$$

$$W_d = \frac{2 W_1}{\text{Number of Shocks Per Rail}}$$

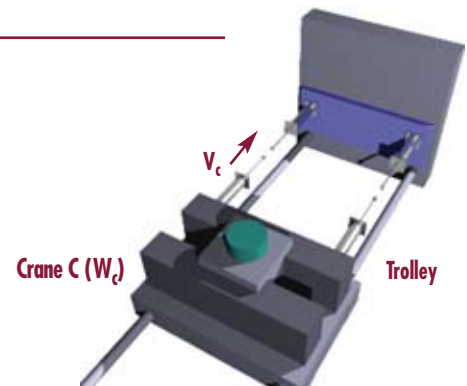

Shock Absorber Sizing Examples

Typical Shock Absorber and Crane Applications

Overview

Please note that this example is not based on any particular standard. The slung load can swing freely, and is therefore not taken into account in the calculation.

Calculation Example for Harbor Cranes as Application 1

Given Values

Bridge Weight:	837,750 lbs.
Weight of Trolley:	99,200 lbs.
Crane Velocity:	60 in./sec.
Required Stroke:	24 in.
Trolley Velocity:	160 in./sec.
Required Stroke:	40 in.

Determination of the Maximum Impact Weight W_d per Buffer

$$W_d = \frac{W_a + (1.8) W_{ta}}{\text{Total Number of Shocks}}$$

$$W_d = \frac{837,750 + (1.8)(99,200)}{2}$$

$W_d = 508,155$ lbs.

Determine Size of Shock Absorber for Crane

$$E_K = \frac{W_d}{772} \cdot V_r^2$$

$$E_K = \frac{508,155 \text{ lbs.}}{772} \cdot (60 \text{ in./sec.})^2$$

$E_K = 2,369,635$ in-lbs.

Selecting for required 24-inch stroke:
HD 5.0 x 24, maximum shock force ca. 116,159 lbs = $F_s = \frac{E_K}{s \cdot \eta}$

$V_r = V_a$ (Application 1)
 E_K = Kinetic Energy
 η = Efficiency

Determine Size of Shock Absorber for Trolley

W_t = Trolley Weight per Shock Absorber

$$W_t = \frac{99,200 \text{ lbs.}}{2}$$

$W_t = 49,600$ lbs.

$$E_K = \frac{W_t}{772} \cdot V_t^2$$

$$E_K = \frac{49,600 \text{ lbs.}}{772} \cdot (160 \text{ in./sec.})^2$$

$E_K = 1,644,767$ in-lbs.

Selecting for required 40-inch stroke:
HDN 4.0 x 40, maximum shock force ca. 48,376 lbs. = $F_s = \frac{E_K}{s \cdot \eta}$

Heavy Duty Shock Absorbers

HDN, HDA Series

Overview

ITT Enidine Inc. Heavy Duty Series large-bore hydraulic shock absorbers protect equipment from large impacts in applications such as automated storage and retrieval systems, as well as overhead bridge and trolley cranes. They are available in a wide variety of stroke lengths and damping characteristics to increase equipment life and meet stringent deceleration requirements.

HDN Series

Custom-orificed design accommodates specified damping requirements. Computer generated output performance simulation is used to optimize the orifice configuration. Available in standard bore dimensions of up to 4 in. (100mm) and strokes over 60 in. (1524mm).

HDA Series

Adjustable units enable the user to modify shock absorber resistance to accommodate load velocity variations, with strokes up to 12in. (305mm). Standard adjustable configurations available.



Features and Benefits HDN, HDA

- Designed with Environmentally friendly materials and fluids
- Compact design smoothly and safely decelerates large energy capacity loads up to 3,000,000 in-lbs. per cycle (330 000 Nm)
- Internal charged air/oil accumulator replaces mechanical return springs, providing shorter overall length and reduced weight.
Optional Bladder Accumulator (BA) for higher cycle rates also available.
- Engineered to meet OSHA, AISE, CMAA and other safety specifications such as DIN and FEM.
- Wide variety of optional configurations including bellows, clevis mounts and safety cables.
- Painted external components provide excellent corrosion protection.
- Epoxy painting and special rod materials are available for use in highly corrosive environments.
- All sizes are fully field repairable.
- Piston rod extension sensor systems available for re-use safety requirements.
- Incorporating optional fluids and seal packages can expand standard operating temperature range from 15°F to 140°F (-10°C to 60°C) to -30°F to 210°F (-35°C to 100°C)

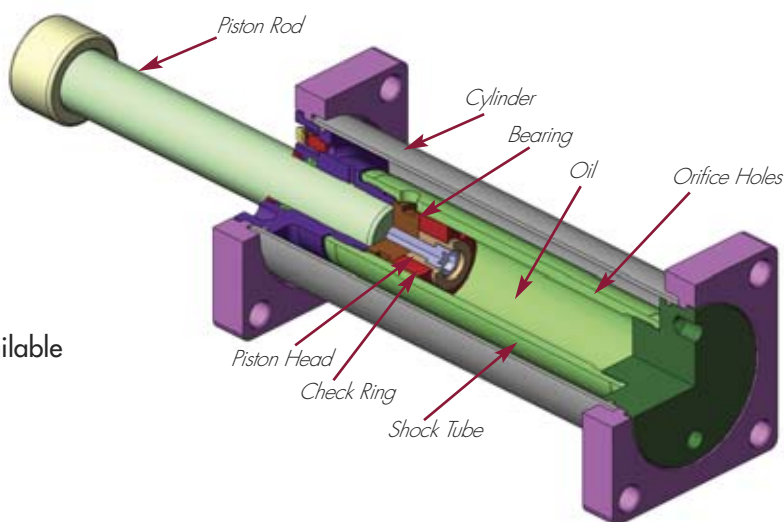

Heavy Duty Shock Absorbers

HDN 1.5 Series

Technical Data

HDN 1.5 x 2 → HDN 1.5 x 32 Series

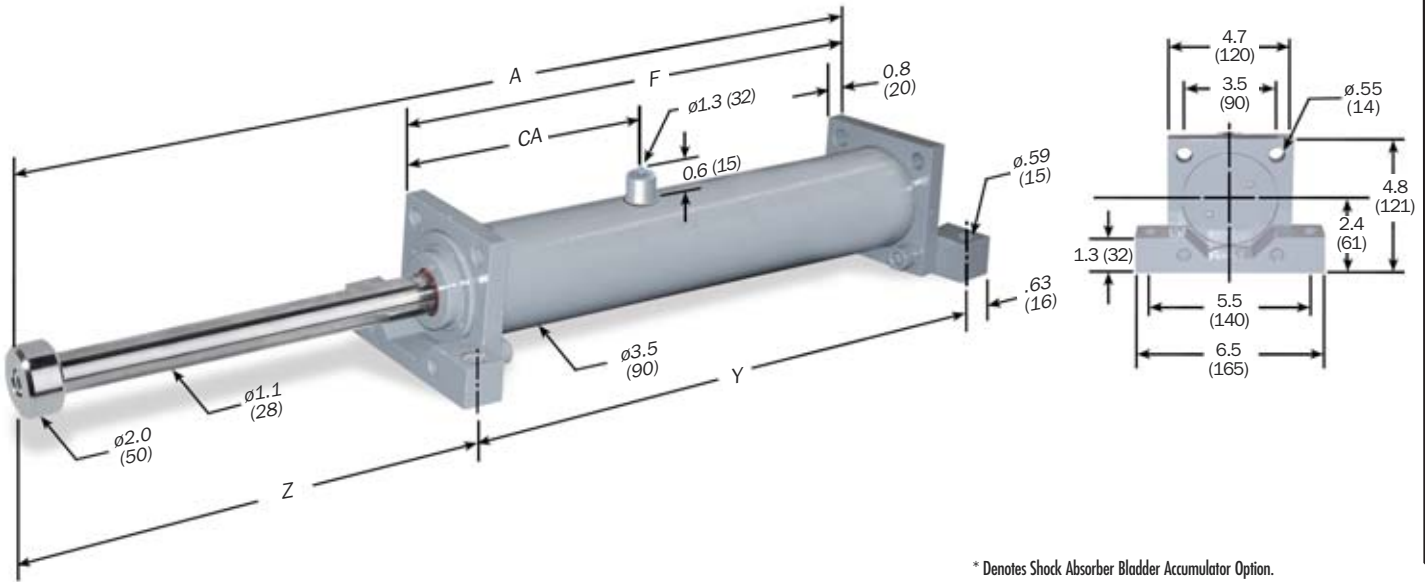

Dimensions are in inches (millimeters).

* Denotes Shock Absorber Bladder Accumulator Option.

Note: For TF, FF and FR mounting, delete front foot and dimensions.

Catalog No./ Model	(S) Stroke in. (mm)	(E _T) Max. in.-lbs./cycle (Nm/cycle)	(E _T C) Max. in.-lbs./hour (Nm/hr)	(F _T) Max. Shock Force lbs. (N)	Nominal Return Force BA* lbs. (N)	Nominal Return Force w/o BA* lbs. (N)	A in. (mm)	F in. (mm)	Y in. (mm)	Z in. (mm)	CA BA* in. (mm)	CA w/o BA* in. (mm)	Model Weight lbs. (Kg)
HDN 1.5 x 2	2 (50)	27,900 (3 200)	1,676,000 (189 000)	15,750 (70 060)	50 (220)	70 (320)	12.2 (310)	8.2 (208)	9.4 (240)	3.4 (86)	5.5 (139)	1.6 (41)	22 (10)
HDN 1.5 x 4	4 (100)	54,200 (6 100)	3,257,300 (368 000)	15,750 (70 060)	50 (220)	90 (410)	16.1 (410)	10.2 (258)	11.4 (290)	5.4 (136)	5.5 (139)	1.6 (41)	24 (12)
HDN 1.5 x 6	6 (150)	80,600 (9 100)	4,838,500 (546 700)	15,750 (70 060)	50 (220)	100 (450)	20.1 (510)	12.1 (308)	13.4 (340)	7.3 (186)	5.5 (139)	1.6 (41)	26 (12)
HDN 1.5 x 8	8 (200)	108,000 (12 200)	6,482,900 (732 500)	15,750 (70 060)	50 (220)	120 (525)	24.1 (613)	14.2 (360)	15.4 (392)	9.3 (237)	5.5 (139)	1.6 (41)	29 (13)
HDN 1.5 x 10	10 (250)	134,900 (15 200)	6,912,000 (781 000)	15,750 (70 060)	50 (220)	135 (600)	28.2 (715)	16.2 (411)	17.4 (443)	11.3 (288)	5.5 (139)	1.6 (41)	31 (14)
HDN 1.5 x 12	12 (300)	161,800 (18 300)	7,769,700 (877,900)	15,750 (70 060)	50 (220)	210 (920)	32.2 (817)	18.2 (462)	19.4 (494)	13.3 (339)	5.5 (139)	1.6 (41)	35 (16)
HDN 1.5 x 14	14 (350)	185,100 (20 900)	8,610,500 (972,900)	15,750 (70 060)	50 (220)	250 (1 120)	36.1 (918)	20.2 (512)	21.4 (544)	15.4 (390)	5.5 (139)	1.6 (41)	37 (17)
HDN 1.5 x 16	16 (400)	208,300 (23 300)	9,468,200 (1 069 800)	13,500 (60 060)	50 (220)	250 (1 120)	40.1 (1 019)	22.2 (563)	23.4 (595)	17.3 (440)	5.5 (139)	1.6 (41)	40 (18)
HDN 1.5 x 18	18 (450)	224,300 (25 300)	10,325,900 (1 166 700)	10,750 (47 820)	50 (220)	250 (1 120)	44.1 (1 121)	24.2 (614)	25.4 (646)	19.3 (491)	5.5 (139)	1.6 (41)	42 (19)
HDN 1.5 x 20	20 (500)	240,300 (27 200)	11,183,600 (1 263 600)	8,750 (38 920)	50 (220)	250 (1 120)	48.2 (1 223)	26.2 (665)	27.4 (697)	21.4 (542)	5.5 (139)	1.6 (41)	44 (20)
HDN 1.5 x 24	24 (600)	269,600 (30 500)	12,899,000 (1 457 400)	6,250 (27 800)	50 (220)	250 (1 120)	56.2 (1 427)	30.2 (767)	31.5 (799)	21.3 (544)	5.5 (139)	1.6 (41)	50 (23)
HDN 1.5 x 28	28 (713)	297,000 (33 600)	14,597,600 (1 649 300)	4,750 (21,130)	50 (220)	250 (1 120)	64.1 (1 629)	34.2 (868)	35.4 (900)	29.3 (745)	5.5 (139)	1.6 (41)	44 (20)
HDN 1.5 x 32	32 (813)	322,800 (36 500)	16,279,300 (1 839 300)	3,700 (16 460)	50 (220)	250 (1 120)	72.0 (1 830)	38.1 (968)	39.4 (1 000)	33.3 (846)	5.5 (139)	1.6 (41)	50 (23)

Notes: 1. HDN shock absorbers will function satisfactorily at 5% of their maximum rated energy per cycle. If less than these values, a smaller model should be specified.

2. It is recommended that the customer consult ITT Eridine Inc. for safety-related overhead crane applications.

3. The energy data listed is for ideal linear impacts only. If side load conditions exist in the application, contact ITT Eridine Inc. for sizing assistance.

4. Rear flange mounting of 12 inch (300 mm) strokes and longer not recommended. Front and rear flange or foot mount configurations are recommended.

5. Maximum cycle rate is 60 cycles/hr. for HDN with BA option and 30 cycles/hr. without BA option.

6. For impact velocities over 180 in./sec. (4.5 m/s), consult factory.

Heavy Duty Series Shock Absorber

HDN 2.0 Series

Technical Data

HDN 2.0 x 6 → HDN 2.0 x 56 Series

Heavy Duty Series

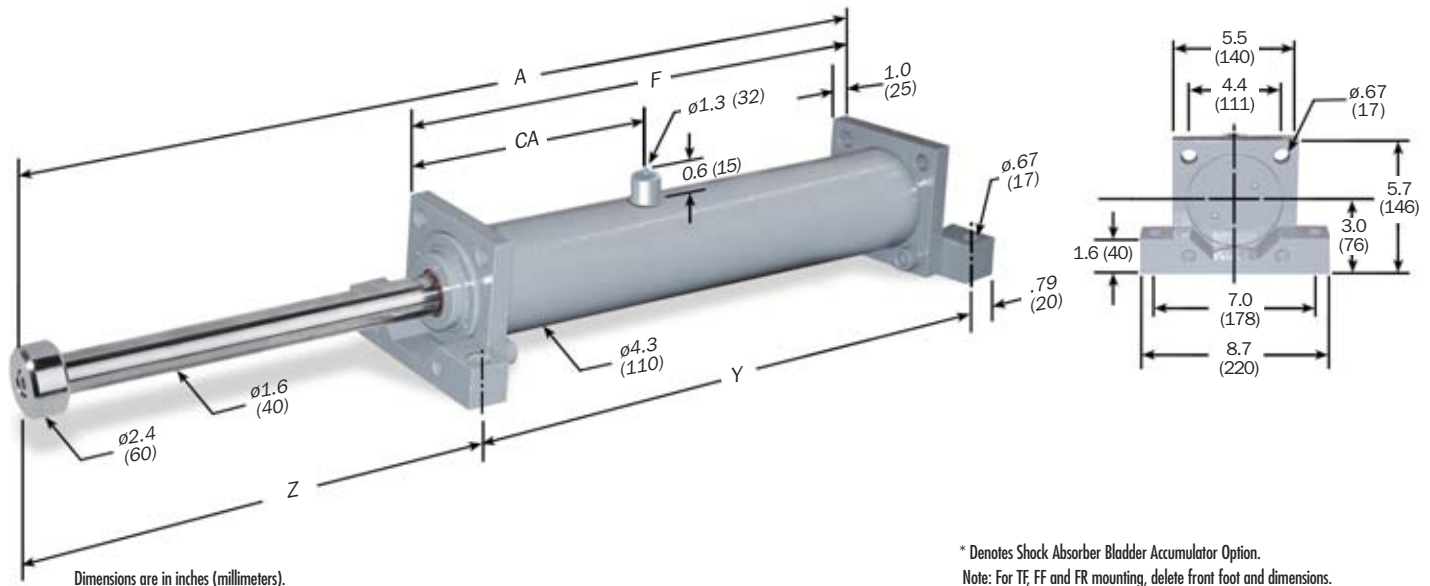

Catalog No./ Model	(S) Stroke in. (mm)	(E _T) Max. in.-lbs./cycle (Nm/cycle)	(E _{T-C}) Max. in.-lbs./hour (Nm/hr)	(F _P) Max. Shock Force lbs. (N)	Nominal Return Force BA* lbs. (N)	Nominal Return Force w/o BA* lbs. (N)	A in. (mm)	F in. (mm)	Y in. (mm)	Z in. (mm)	CA in. (mm)	CA w/o BA* in. (mm)	Model Weight lbs. (Kg)
HDN 2.0 x 6	6 (152)	127,200 (14 400)	7,629,900 (862 100)	25,000 (111 200)	120 (535)	200 (870)	21.8 (553)	13.3 (339)	14.9 (379)	7.6 (194)	6.9 (176)	1.8 (46)	51 (23)
HDN 2.0 x 8	8 (203)	169,800 (19 200)	8,086,900 (913 700)	25,000 (111 200)	120 (535)	235 (1 040)	25.8 (655)	15.4 (390)	16.9 (430)	9.6 (245)	6.9 (176)	1.8 (46)	55 (25)
HDN 2.0 x 10	10 (250)	212,500 (24 000)	9,144,400 (1 033 200)	25,000 (111 200)	120 (535)	300 (1 340)	29.8 (757)	17.4 (441)	18.9 (481)	11.7 (296)	6.9 (176)	1.8 (46)	51 (23)
HDN 2.0 x 12	12 (300)	253,200 (28 600)	10,201,900 (1 152 700)	25,000 (111 200)	120 (535)	515 (2 290)	33.8 (859)	19.4 (492)	20.9 (532)	13.7 (347)	6.9 (176)	1.8 (46)	55 (25)
HDN 2.0 x 14	14 (350)	285,900 (32 300)	11,259,500 (1 272 100)	25,000 (111 200)	120 (535)	515 (2 290)	37.8 (960)	21.4 (543)	23.0 (583)	15.6 (397)	6.9 (176)	1.8 (46)	60 (27)
HDN 2.0 x 16	16 (400)	318,700 (36 000)	12,317,000 (1 391 600)	25,000 (111 200)	120 (535)	515 (2 290)	41.8 (1 062)	23.4 (594)	25.0 (634)	17.6 (448)	6.9 (176)	1.8 (46)	64 (29)
HDN 2.0 x 18	18 (450)	351,500 (39 700)	13,374,500 (1 511 100)	25,000 (111 200)	120 (535)	515 (2 290)	45.8 (1 164)	25.4 (645)	27.0 (685)	19.6 (499)	6.9 (176)	1.8 (46)	68 (31)
HDN 2.0 x 20	20 (500)	383,600 (43 300)	14,411,300 (1 628 300)	25,000 (111 200)	120 (535)	515 (2 290)	49.8 (1 265)	27.4 (695)	28.9 (735)	21.7 (550)	6.9 (176)	1.8 (46)	73 (33)
HDN 2.0 x 24	24 (600)	449,100 (50 700)	16,526,300 (1 867 200)	25,000 (111 200)	120 (535)	515 (2 290)	57.8 (1 469)	31.4 (797)	33.0 (837)	25.7 (652)	6.9 (176)	1.8 (46)	79 (36)
HDN 2.0 x 28	28 (700)	514,678 (58 200)	18,641,400 (2 106 200)	25,000 (111 200)	120 (535)	515 (2 290)	65.8 (1 672)	35.4 (899)	37.0 (939)	29.6 (753)	6.9 (176)	1.8 (46)	93 (42)
HDN 2.0 x 32	32 (800)	625,600 (70 700)	22,373,800 (2 527 900)	25,000 (111 200)	120 (535)	515 (2 290)	76.9 (1 953)	42.5 (1 079)	44.1 (1 119)	33.6 (854)	10.1 (256)	1.8 (46)	108 (49)
HDN 2.0 x 36	36 (900)	689,500 (77 900)	24,447,300 (2 762 200)	22,500 (100 000)	120 (535)	515 (2 290)	84.7 (2 151)	46.4 (1 179)	48.0 (1 219)	37.5 (952)	10.1 (256)	1.8 (46)	117 (53)
HDN 2.0 x 40	40 (1 000)	746,700 (84,400)	26,520,900 (2 996 500)	19,000 (84 500)	120 (535)	515 (2 290)	92.6 (2 351)	50.4 (1 279)	51.9 (1 319)	41.4 (1 052)	10.1 (256)	1.8 (46)	124 (56)
HDN 2.0 x 48	48 (1 200)	844,100 (95 400)	30,668,000 (3 465 000)	13,500 (60 000)	120 (535)	515 (2 290)	108.3 (2 751)	58.2 (1 479)	59.8 (1 519)	49.3 (1 252)	10.1 (256)	1.8 (46)	141 (64)
HDN 2.0 x 56	56 (1 400)	922,300 (104 200)	35,022,500 (3 957 000)	7,900 (35 100)	120 (535)	515 (2 290)	124.8 (3 171)	66.5 (1 689)	68.1 (1 729)	57.6 (1 462)	10.1/38.4** (256/975)	1.8 (46)	161 (73)

1. HDN shock absorbers will function satisfactorily at 5% of their maximum rated energy per cycle. If less than these values, a smaller model should be specified.
2. It is recommended that the customer consult ITT Enidine Inc. for safety-related overhead crane applications.
3. The energy data listed is for ideal linear impacts only. If side load conditions exist in the application, contact ITT Enidine Inc. for sizing assistance.
4. Rear flange mounting of 12 inch (300 mm) strokes and longer not recommended. Front and rear flange or foot mount configurations are recommended.
5. Maximum cycle rate is 60 cycles/hr. for HDN with BA option and 30 cycles/hr. without BA option.
6. For impact velocities over 180 in./sec. (4.5 m/s), consult factory.
7. ** HDN 2.0 x 56 has two charge ports.

Heavy Duty Series Shock Absorber

HDN 3.5 Series

Technical Data

HDN 3.5 x 2 → HDN 3.5 x 56 Series

Heavy Duty Series

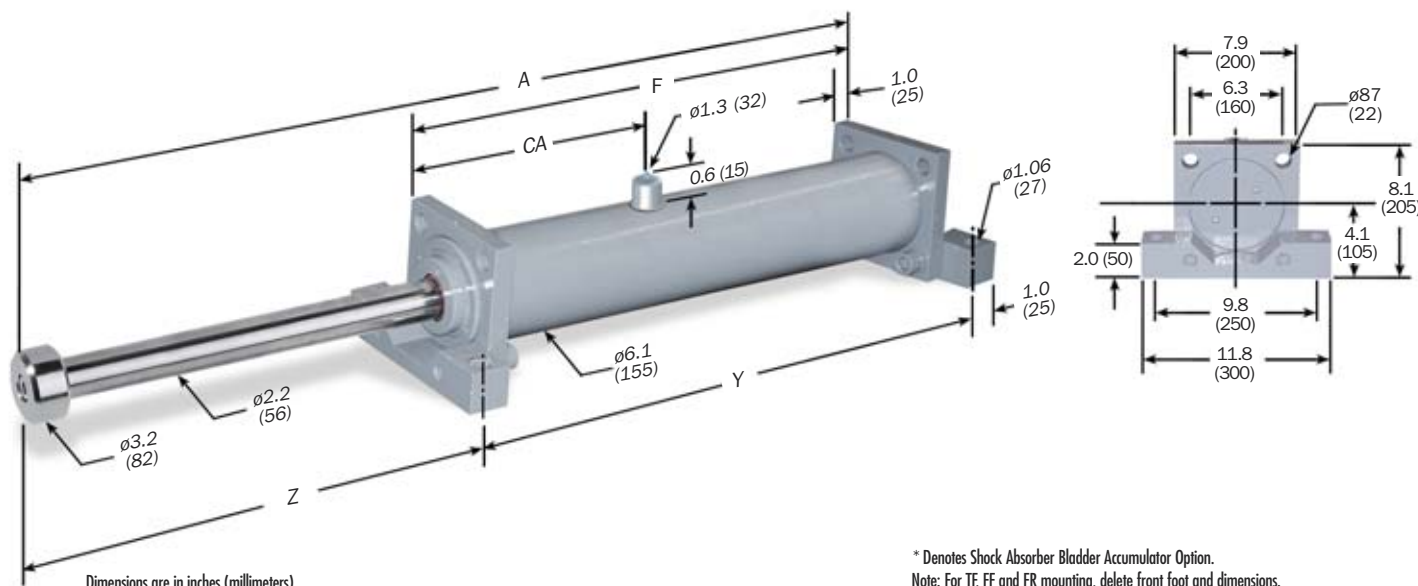

Catalog No./ Model	(S) Stroke in. (mm)	(E _P) Max. in.-lbs./cycle (Nm/cycle)	(E _C) Max. in.-lbs./hour (Nm/hr)	(F _P) Max. Shock Force lbs. (N)	Nominal Return Force BA* lbs. (N)	Nominal Return Force w/o BA* lbs. (N)	A in. (mm)	F in. (mm)	Y in. (mm)	Z in. (mm)	CA in. (mm)	CA w/o BA* in. (mm)	Model Weight lbs. (Kg)
HDN 3.5 x 2	2 (50)	115,200 (13 000)	6,912,100 (781 000)	67,500 (300 250)	215 (960)	455 (2 020)	13.9 (354)	9.6 (244)	11.6 (294)	3.3 (85)	5.3 (134)	2.1 (52)	73 (33)
HDN 3.5 x 4	4 (100)	230,400 (26 000)	8,793,200 (993 500)	67,500 (300 250)	230 (1 020)	610 (2 710)	18.0 (456)	11.6 (295)	13.6 (345)	5.4 (136)	5.3 (134)	2.1 (52)	82 (37)
HDN 3.5 x 6	6 (150)	343,300 (38 800)	10,283,600 (1 161 900)	67,500 (300 250)	260 (1 160)	1,010 (4 480)	21.9 (556)	13.6 (345)	15.6 (395)	7.3 (186)	5.3 (134)	2.1 (52)	90 (41)
HDN 3.5 x 8	8 (200)	450,300 (50 900)	11,803,800 (1 333 600)	67,500 (300 250)	265 (1 180)	1,010 (4 480)	25.9 (658)	15.6 (396)	17.6 (446)	9.3 (237)	5.3 (134)	2.1 (52)	99 (45)
HDN 3.5 x 10	10 (250)	538,400 (60 800)	13,324,000 (1 505 400)	67,500 (300 250)	270 (1 200)	1,010 (4 480)	29.9 (760)	17.6 (447)	19.6 (497)	11.3 (288)	5.3 (134)	2.1 (52)	108 (49)
HDN 3.5 x 12	12 (300)	626,500 (70 800)	14,844,100 (1 677 200)	67,500 (300 250)	270 (1 200)	1,010 (4 480)	33.9 (862)	19.6 (498)	21.6 (548)	13.3 (339)	5.3 (134)	2.1 (52)	117 (53)
HDN 3.5 x 16	16 (400)	801,000 (90 500)	17,854,700 (2 017 300)	67,500 (300 250)	275 (1 225)	1,010 (4 480)	41.9 (1 064)	23.6 (599)	25.6 (649)	17.3 (440)	5.3 (134)	2.1 (52)	132 (60)
HDN 3.5 x 20	20 (500)	1,051,800 (118 800)	22,534,500 (2 546 100)	67,500 (300 250)	275 (1 225)	1,010 (4 480)	52.0 (1 323)	29.8 (756)	31.8 (806)	21.2 (542)	7.4 (189)	2.1 (52)	163 (74)
HDN 3.5 x 24	24 (600)	1,228,000 (138 700)	25,574,800 (2 889 600)	67,500 (300 250)	280 (1 250)	1,010 (4 480)	60.1 (1 527)	33.8 (858)	35.8 (908)	25.3 (644)	7.4 (189)	2.1 (52)	179 (81)
HDN 3.5 x 28	28 (700)	1,402,500 (158 500)	28,585,400 (3 229 700)	67,500 (300 250)	280 (1 250)	1,010 (4 480)	68.0 (1 729)	37.8 (959)	39.8 (1 009)	29.2 (745)	7.4 (189)	2.1 (52)	196 (89)
HDN 3.5 x 32	32 (800)	1,578,700 (178 400)	31,625,800 (3 573 200)	67,500 (300 250)	280 (1 250)	1,010 (4 480)	76.1 (1 933)	41.8 (1 061)	43.8 (1 111)	33.2 (847)	7.4 (189)	2.1 (52)	214 (97)
HDN 3.5 x 36	36 (900)	1,754,900 (198 300)	34,666,100 (3 916 800)	58,500 (260 200)	280 (1 250)	1,010 (4 480)	84.1 (2 137)	45.8 (1 163)	47.8 (1 213)	37.3 (949)	7.4 (189)	2.1 (52)	231 (105)
HDN 3.5 x 40	40 (1 000)	1,918,600 (216 800)	37,676,700 (4 256 900)	48,500 (215 700)	280 (1 250)	1,010 (4 480)	92.1 (2 339)	49.8 (1 264)	51.8 (1 314)	41.3 (1 050)	7.4 (189)	2.1 (52)	247 (112)
HDN 3.5 x 48	48 (1 200)	2,188,000 (247 200)	43,638,200 (4 930 500)	35,000 (155 700)	280 (1 250)	1,010 (4 480)	107.8 (2 739)	57.6 (1 464)	59.6 (1 514)	49.2 (1 250)	7.4 (189)	2.1 (52)	282 (128)
HDN 3.5 x 56	56 (1 400)	2,418,600 (273 300)	49,599,700 (5 604 000)	25,300 (112 500)	470 (2 100)	1,010 (4 480)	107.8 (2 739)	57.6 (1 464)	59.6 (1 514)	49.2 (1 250)	7.4/35.7** (189/908)	2.1 (52)	282 (128)

- Notes: 1. HDN shock absorbers will function satisfactorily at 5% of their maximum rated energy per cycle. If less than these values, a smaller model should be specified.
 2. It is recommended that the customer consult ITT Enidine Inc. for safety-related overhead crane applications.
 3. The energy data listed is for ideal linear impacts only. If side load conditions exist in the application, contact ITT Enidine Inc. for sizing assistance.
 4. Rear flange mounting of 12 inch (300 mm) strokes and longer not recommended. Front and rear flange or foot mount configurations are recommended.
 5. Maximum cycle rate is 60 cycles/hr. for HDN with BA option and 30 cycles/hr. without BA option.
 6. For impact velocities over 180 in./sec. (4.5 m/s), consult factory.
 7. ** HDN 3.5 x 56 has two charge ports.

Heavy Duty Series Shock Absorber

HDN 4.0 Series

Technical Data

HDN 4.0 x 2 → HDN 4.0 x 48 Series

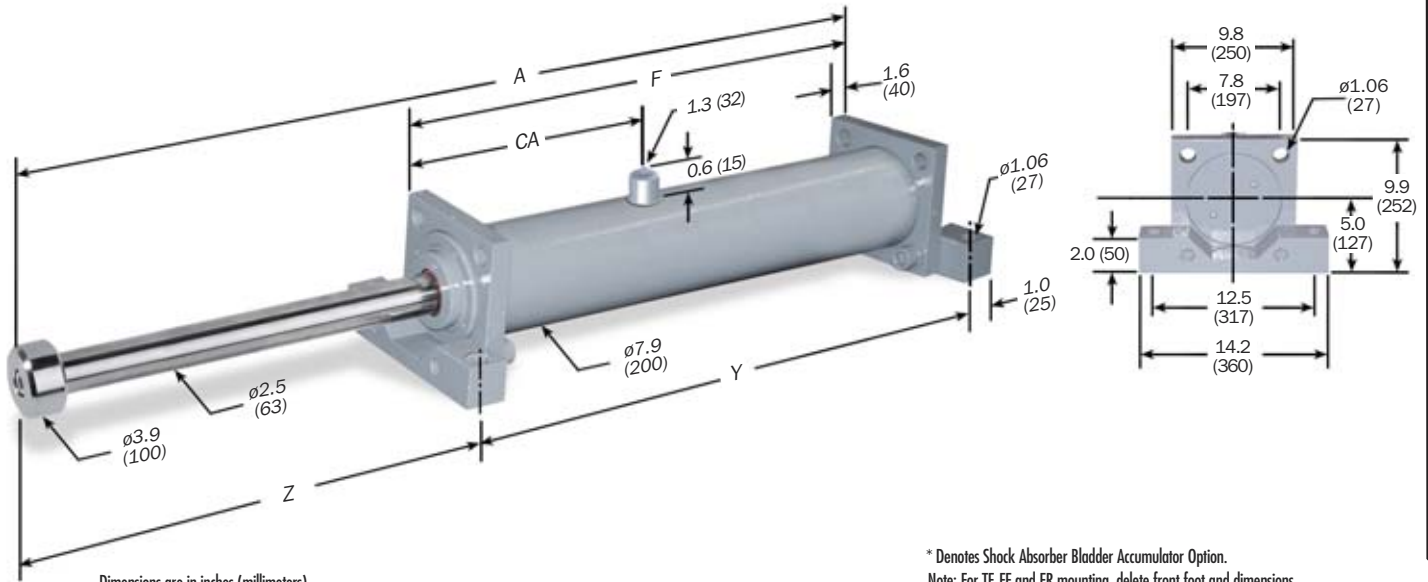

Catalog No./ Model	(S) Stroke in. (mm)	(F _p) Max. in.-lbs./cycle (Nm/cycle)	(E _{T-C}) Max. in.-lbs./hour (Nm/hr)	(F _p) Max. Initial Shock Force lbs. (N)	Nominal Return Force BA* lbs. (N)	Nominal Return Force w/o BA* lbs. (N)	A in. (mm)	F in. (mm)	Y in. (mm)	Z in. (mm)	CA BA* in. (mm)	CA w/o BA* in. (mm)	Model Weight lbs. (Kg)
HDN 4.0 x 2	2 (50)	139,200 (15 700)	8,352,800 (943 700)	80,000 (355 900)	250 (1 100)	425 (1 900)	16.9 (430)	11.6 (294)	13.5 (344)	4.4 (111)	8.1 (206)	2.5 (64)	141 (64)
HDN 4.0 x 4	4 (100)	275,700 (31 200)	13,579,600 (1 534 300)	80,000 (355 900)	270 (1 200)	485 (2 160)	20.9 (532)	13.6 (345)	15.6 (395)	6.4 (162)	8.1 (206)	2.5 (64)	154 (70)
HDN 4.0 x 6	6 (150)	409,606 (46 279)	15,547,700 (1 756 700)	80,000 (355 900)	270 (1 200)	690 (3 050)	24.9 (632)	15.6 (395)	17.5 (445)	8.3 (212)	8.1 (206)	2.5 (64)	168 (76)
HDN 4.0 x 8	8 (200)	548,800 (62 000)	17,594,400 (1 987 900)	80,000 (355 900)	270 (1 200)	980 (4 370)	28.9 (735)	17.6 (447)	19.6 (497)	10.4 (263)	8.1 (206)	2.5 (64)	181 (82)
HDN 4.0 x 10	10 (250)	682,700 (77,100)	19,562,500 (2 210 300)	80,000 (355 900)	270 (1 200)	1,230 (5 465)	32.9 (836)	19.6 (497)	21.5 (547)	12.4 (314)	8.1 (206)	2.5 (64)	192 (87)
HDN 4.0 x 12	12 (300)	819,200 (92 600)	25,269,900 (1 855 100)	80,000 (355 900)	275 (1 225)	1,000 (4 440)	40.6 (1 032)	25.3 (642)	27.2 (692)	14.4 (365)	11.8 (300)	2.5 (64)	238 (108)
HDN 4.0 x 16	16 (400)	1,089,600 (123,100)	29,245,400 (3 304 300)	80,000 (355 900)	275 (1 225)	1,270 (5 650)	48.6 (1 234)	29.3 (743)	31.2 (793)	18.3 (466)	11.8 (300)	2.5 (64)	265 (120)
HDN 4.0 x 20	20 (500)	1,362,700 (154 000)	33,260,200 (3 757 900)	80,000 (355 900)	280 (1 245)	1,155 (5 145)	56.6 (1 438)	33.3 (845)	35.2 (895)	22.4 (568)	11.8 (300)	2.5 (64)	290 (131)
HDN 4.0 x 24	24 (600)	1,635,700 (184 800)	37,275,000 (4 211 500)	80,000 (355 900)	280 (1 245)	1,275 (5 675)	64.6 (1 642)	37.3 (947)	39.3 (997)	26.4 (670)	11.8 (300)	2.5 (64)	317 (144)
HDN 4.0 x 28	28 (700)	1,904,200 (215 100)	41,250,500 (4 660 700)	80,000 (355 900)	280 (1 245)	1,275 (5 675)	72.6 (1 844)	41.3 (1 048)	43.2 (1 098)	30.4 (771)	11.8 (300)	2.5 (64)	346 (157)
HDN 4.0 x 32	32 (800)	2,128,700 (240 500)	45,265,400 (5 114 300)	80,000 (355 900)	280 (1 245)	1,275 (5 675)	80.6 (2 048)	45.3 (1 150)	47.2 (1 200)	34.4 (873)	11.8 (300)	2.5 (64)	375 (170)
HDN 4.0 x 36	36 (900)	2,353,200 (265 900)	49,280,200 (5 567 900)	80,000 (355 900)	280 (1 245)	1,275 (5 675)	88.7 (2 252)	49.3 (1 252)	51.3 (1 302)	38.4 (975)	11.8 (300)	2.5 (64)	403 (183)
HDN 4.0 x 40	40 (1 000)	2,566,000 (289 900)	53,255,700 (6 017 100)	80,000 (355 900)	280 (1 245)	1,275 (5 675)	96.6 (2 454)	53.3 (1 353)	55.2 (1 403)	42.4 (1 076)	11.8 (300)	2.5 (64)	430 (195)
HDN 4.0 x 48	48 (1 200)	2,914,200 (329 300)	61,246,000 (6 919 900)	45,000 (200 000)	280 (1 245)	1,275 (5 675)	112.4 (2 854)	61.3 (1 556)	63.2 (1 606)	50.1 (1 273)	11.8 (300)	2.5 (64)	485 (220)

Notes: 1. HDN shock absorbers will function satisfactorily at 5% of their maximum rated energy per cycle. If less than these values, a smaller model should be specified.

2. It is recommended that the customer consult ITT Enidine Inc. for safety-related overhead crane applications.

3. The energy data listed is for ideal linear impacts only. If side load conditions exist in the application, contact ITT Enidine Inc. for sizing assistance.

4. Rear flange mounting of 12 inch (300 mm) strokes and longer not recommended. Front and rear flange or foot mount configurations are recommended.

5. Maximum cycle rate is 60 cycles/hr. for HDN with BA option and 30 cycles/hr. without BA option.

6. For impact velocities over 180 in./sec. (4.5 m/s), consult factory.

Heavy Duty Adjustable Series Shock Absorber

HDA 3.0 Series

Technical Data

HDA 3.0 x 2 → HDA 3.0 x 12 Series

Heavy Duty Series

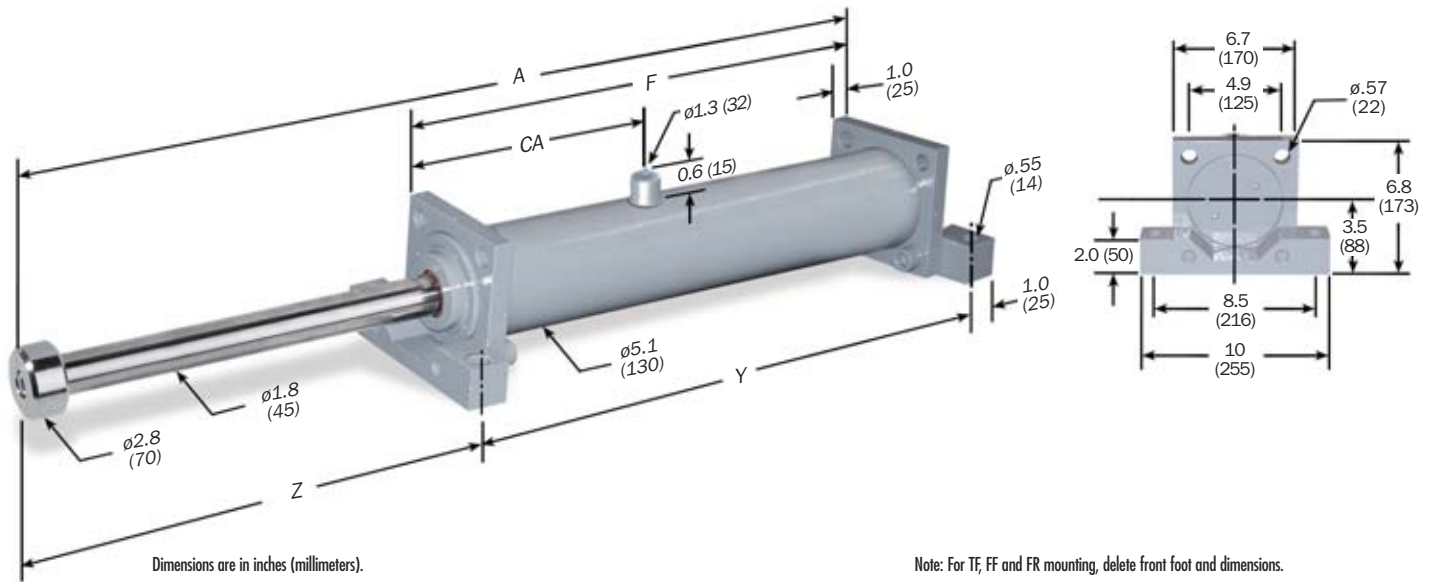

Catalog No./ Model	(S) Stroke in. (mm)	(E _T) Max. in.-lbs./cycle (Nm/cycle)	(E _C) Max. in.-lbs./hour (Nm/hr)	(F _P) Max. End Shock Force lbs. (N)	Nominal Return Force BA* lbs. (N)	A in. (mm)	F in. (mm)	Y in. (mm)	Z in. (mm)	CA* in. (mm)	Model Weight lbs. (Kg)
HDA 3.0 x 2	2 (50)	40,000 (4 500)	2,400,000 (271 200)	50,000 (222 400)	150 (660)	13.2 (336)	8.4 (213)	10.4 (263)	3.9 (98)	4.4 (112)	40 (21)
HDA 3.0 x 3	3 (75)	60,000 (6 800)	3,600,000 (406 700)	50,000 (222 400)	160 (710)	15.2 (387)	9.4 (239)	11.4 (289)	4.8 (123)	4.4 (112)	42 (22)
HDA 3.0 x 5	5 (125)	100,000 (11 300)	6,000,000 (677 900)	50,000 (222 400)	165 (730)	19.3 (489)	11.4 (290)	13.4 (340)	6.9 (174)	4.4 (112)	48 (25)
HDA 3.0 x 8	8 (200)	160,000 (18 100)	9,296,000 (1 050 300)	50,000 (222 400)	170 (765)	25.2 (640)	14.4 (365)	16.3 (415)	9.8 (250)	4.4 (112)	57 (29)
HDA 3.0 x 10	10 (250)	200,000 (22 600)	10,594,500 (1 197 100)	50,000 (222 400)	175 (775)	29.2 (742)	16.4 (416)	18.3 (466)	11.9 (301)	4.4 (112)	64 (32)
HDA 3.0 x 12	12 (300)	240,000 (27 200)	11,893,800 (1 343 800)	50,000 (222 400)	175 (775)	33.2 (844)	18.4 (467)	20.4 (517)	13.8 (352)	4.4 (112)	71 (35)

- Notes: 1. HDA shock absorbers will function satisfactorily at 5% of their maximum rated energy per cycle. If less than these values, a smaller model should be specified.
 2. It is recommended that the customer consult ITT Enidine Inc. for safety-related overhead crane applications.
 3. The energy data listed is for ideal linear impacts only. If side load conditions exist in the application, contact ITT Enidine Inc. for sizing assistance.
 4. Rear flange mounting of 12 inch (300 mm) strokes and longer not recommended. Front and rear flange or foot mount configurations are recommended.
 5. Maximum cycle rate is 60 cycles/hr.
 6. HDA models which have an impact velocity below 30 in./sec. (.8 m/sec.), please contact ITT Enidine Inc. for assistance.
 7. Maximum allowable applied propelling force: 25,000 lbs. (111 200 N)

Adjustment Techniques

Useable Adjustment Setting Range

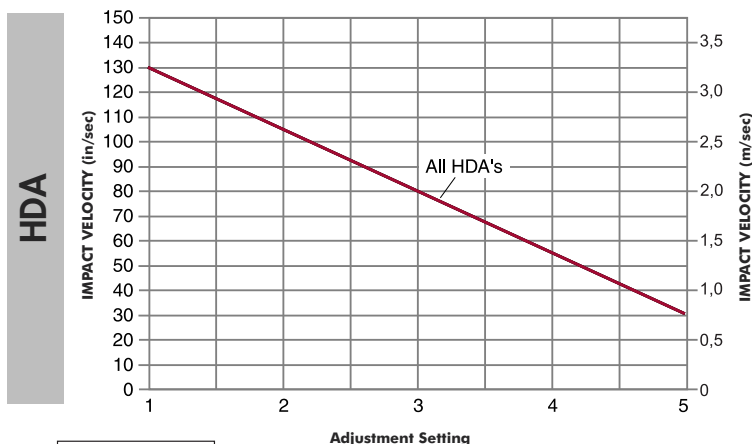

After properly sizing an HDA shock absorber, the useable range of adjustment settings can be determined:

1. Locate the intersection point of the application's impact velocity and the HDA model graph line.
2. The intersection is the maximum adjustment setting to be used. Adjustments exceeding this setting could overload the shock absorber.
3. The useable adjustment setting range is from setting 1 to the MAXIMUM adjustment setting as determined in step 2.

EXAMPLE: HDA Series

1. Impact Velocity: 80 in./sec. (2 m/s)
2. Intersection Point: Adjustment Setting 3
3. Useable Adjustment Setting Range: 1 to 3

Heavy Duty Adjustable Series Shock Absorber

HDA 4.0 Series

Technical Data

HDA 4.0 x 2 → HDA 4.0 x 10 Series

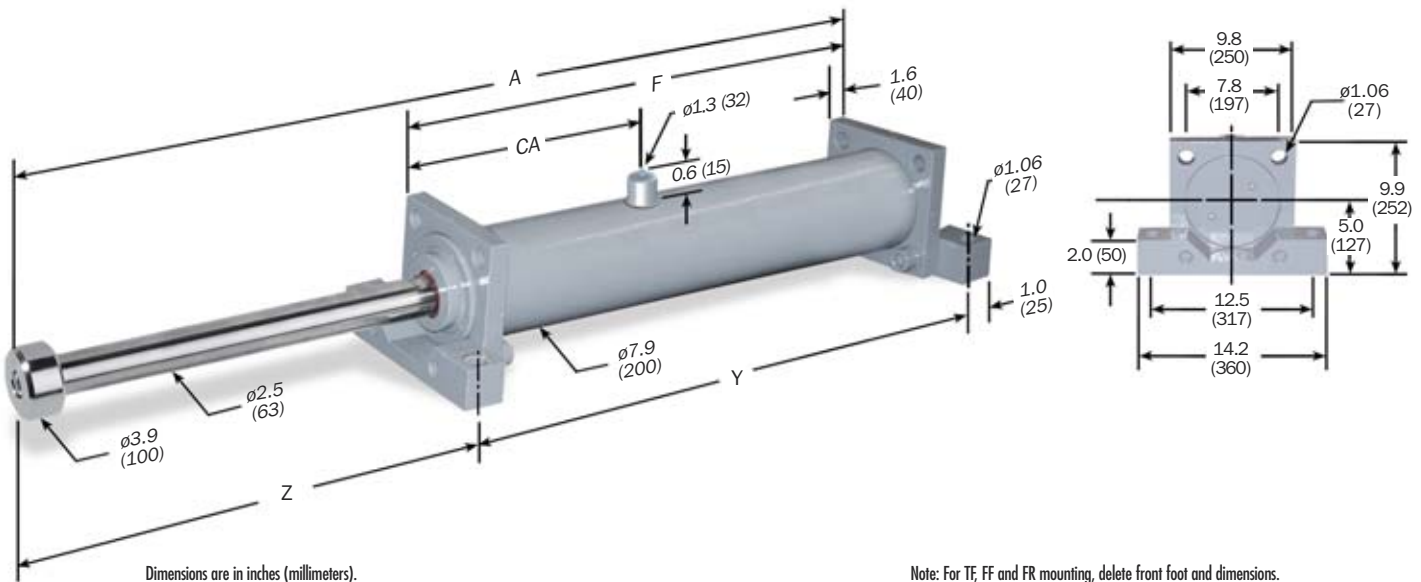

Catalog No./ Model	(S) Stroke in. (mm)	(E _T) Max. in.-lbs./cycle (Nm/cycle)	(E _T C) Max. in.-lbs./hour (Nm/hr)	(F _P) Max. Shock Force lbs. (N)	Nominal Return Force BA* lbs. (N)	A in. (mm)	F in. (mm)	Y in. (mm)	Z in. (mm)	CA* in. (mm)	Model Weight lbs. (Kg)
HDA 4.0 x 2	2 (50)	120,000 (13 600)	7,200,000 (813 500)	80,000 (355 900)	250 (1 125)	16.9 (430)	12.0 (304)	13.9 (354)	4.0 (101)	7.1 (180)	141 (64)
HDA 4.0 x 4	4 (100)	240,000 (27 100)	13,973,200 (1 578 800)	80,000 (355 900)	250 (1 125)	20.9 (532)	14.0 (355)	15.9 (405)	6.0 (152)	7.1 (180)	154 (70)
HDA 4.0 x 6	6 (150)	360,000 (40 700)	15,941,300 (1 801 100)	80,000 (355 900)	250 (1 125)	24.9 (632)	15.9 (405)	17.9 (455)	8.0 (202)	7.1 (180)	168 (76)
HDA 4.0 x 8	8 (200)	480,000 (54 200)	17,988,100 (2 032 400)	80,000 (355 900)	250 (1 125)	28.9 (735)	18.0 (457)	20.0 (507)	10.0 (253)	7.1 (180)	181 (82)
HDA 4.0 x 10	10 (250)	600,000 (67 800)	19,956,100 (2 254 700)	80,000 (355 900)	250 (1 125)	32.9 (836)	20.0 (507)	21.9 (557)	12.0 (304)	7.1 (180)	192 (87)

- Notes: 1. HDA shock absorbers will function satisfactorily at 5% of their maximum rated energy per cycle. If less than these values, a smaller model should be specified.
 2. It is recommended that the customer consult ITT Enidine Inc. for safety-related overhead crane applications.
 3. The energy data listed is for ideal linear impacts only. If side load conditions exist in the application, contact ITT Enidine Inc. for sizing assistance.
 4. Rear flange mounting of 12 inch (300 mm) strokes and longer not recommended. Front and rear flange or foot mount configurations are recommended.
 5. Maximum cycle rate is 60 cycles/hr.
 6. HDA models which have an impact velocity below 30 in./sec. (.8 m/sec.), please contact ITT Enidine Inc. for assistance.
 7. Maximum allowable applied propelling force: 40,000 (177 900 N)

Damping Force

Position 1 provides minimum damping force.
 Position 5 provides maximum damping force.

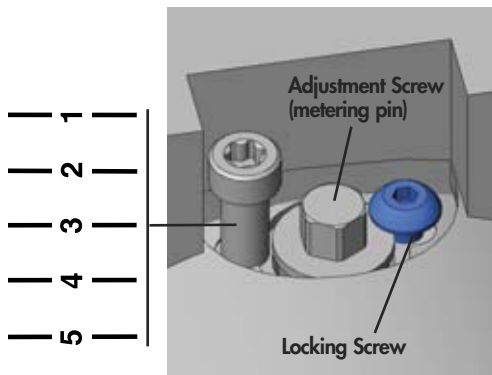

Adjustment Technique

1. Loosen socket head cap screw.
2. Set adjustment screw desired location.
3. Tighten socket head cap screw on shoulder of adjustment screw.

HD Series

Custom-orificed design accommodates specified damping requirements. Computer generated output performance simulation is used to optimize the orifice configuration. Available in standard bore dimensions of up to 5 in. (125mm) and 6 in. (156mm) with strokes over 60 in. (1525mm).



Features and Benefits HD

- Compact design smoothly and safely decelerates large energy capacity loads up to 8,000,000 in-lbs. per cycle (900 000 Nm)
- Engineered to meet OSHA, AISE, CMAA and other safety specifications such as DIN and FEM.
- Internal air charged bladder accumulator replaces mechanical return springs, providing shorter overall length and reduced weight.
- Wide variety of optional configurations including bellows, clevis mounts and safety cables.
- Available in standard adjustable or custom-orificed non-adjustable models.
- Zinc plated external components provide enhanced corrosion protection.
- Epoxy painting and special rod materials are available for use in highly corrosive environments.
- All sizes are fully field repairable.
- Piston rod extension sensor systems available for reuse safety requirements.
- Incorporating optional fluids and seal packages can expand standard operating temperature range from 15°F to 140°F (-30°F to 210°F (-10°C to 60°C) to (-35°C to 100°C)

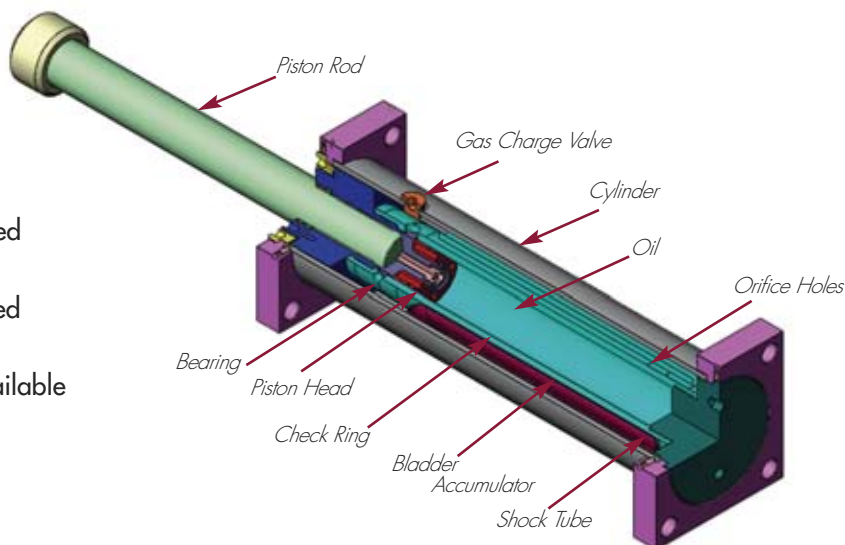

Heavy Duty Series Shock Absorber

HD 6.0 Series

Technical Data

HD 6.0 x 4 → HD 6.0 x 48 Series

Heavy Duty Series

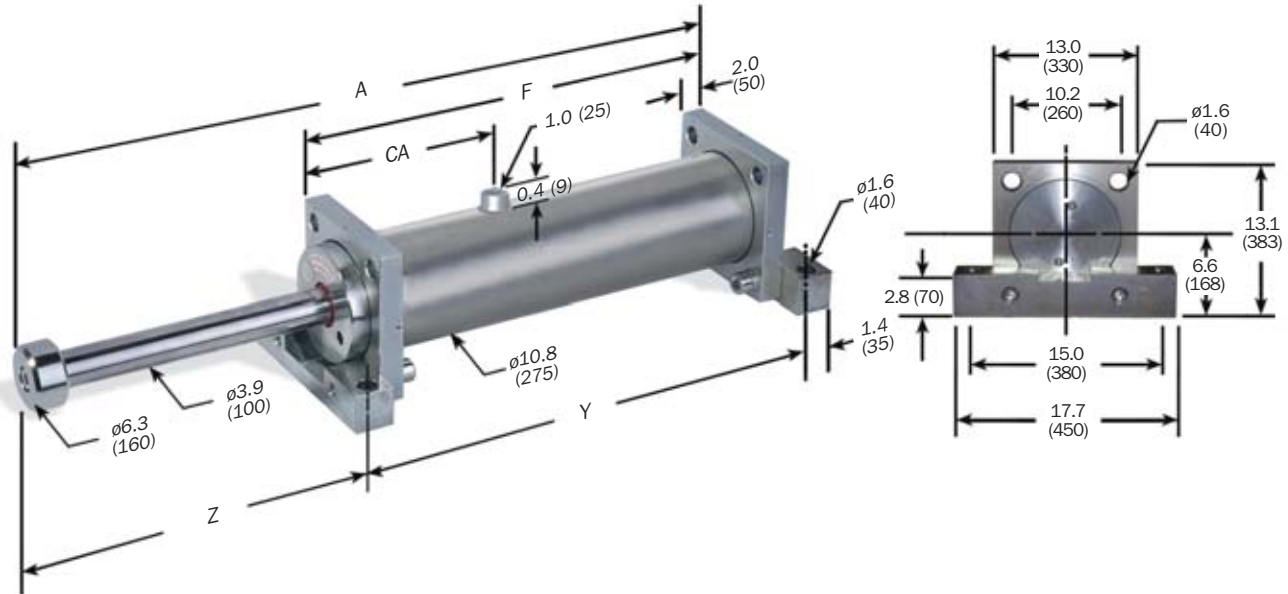

Dimensions are in inches (millimeters).

Note: For TF, FF and FR mounting, delete front foot and dimensions.

Catalog No./ Model	(S) Stroke in. (mm)	(E _T) Max. in.-lbs./cycle (Nm/cycle)	(E _{T-C}) Max. in.-lbs./hour (Nm/hr)	(F _P) Max. Shock Force lbs. (N)	Nominal Return Force BA* lbs. (N)	A in. (mm)	F in. (mm)	Y in. (mm)	Z in. (mm)	CA in. (mm)	Model Weight lbs. (Kg)
HD(A) 6.0 x 4	4 (100)	677,000 (76 500)	21,280,000 (2 404 568)	202,250 (900 000)	625 (2 750)	25.1 (637)	15.4 (391)	18.2 (461)	8.3 (211)	7.8 (197)	362 (164)
HD(A) 6.0 x 6	6 (150)	1,010,000 (114 000)	23,933,000 (2 704 389)	202,250 (900 000)	625 (2 750)	29.1 (737)	17.4 (441)	20.2 (511)	10.3 (261)	7.8 (197)	386 (175)
HD(A) 6.0 x 8	8 (200)	1,354,000 (153 000)	26,586,000 (3 004 211)	202,250 (900 000)	625 (2 750)	33.1 (839)	19.4 (492)	22.2 (562)	12.3 (312)	7.8 (197)	410 (186)
HD(A) 6.0 x 10	10 (250)	1,690,000 (191 000)	29,345,000 (3 316 025)	202,250 (900 000)	625 (2 750)	37.1 (941)	21.4 (543)	24.2 (613)	14.3 (363)	7.8 (197)	432 (196)
HD(A) 6.0 x 12	12 (300)	1,982,000 (224 000)	32,052,000 (3 621 843)	202,250 (900 000)	625 (2 750)	41.1 (1 043)	23.4 (594)	26.2 (664)	16.3 (414)	7.8 (197)	456 (207)
HD 6.0 x 16	16 (400)	2,708,000 (306 000)	37,465,000 (4 233 478)	202,250 (900 000)	625 (2 750)	49.1 (1 246)	27.4 (696)	30.2 (766)	20.3 (515)	7.8 (197)	503 (228)
HD 6.0 x 20	20 (500)	3,380,000 (382 000)	42,877,000 (4 845 114)	202,250 (900 000)	625 (2 750)	57.1 (1 450)	31.4 (798)	34.2 (868)	24.3 (617)	7.8 (197)	551 (250)
HD 6.0 x 24	24 (600)	4,062,000 (459 000)	53,862,000 (6 086 375)	202,250 (900 000)	625 (2 750)	69.7 (1 769)	40.0 (1 015)	42.7 (1 085)	28.4 (719)	12.3 (312)	681 (309)
HD 6.0 x 30	30 (750)	5,070,000 (573 000)	61,928,000 (6 997 832)	202,250 (900 000)	625 (2 750)	81.6 (2 073)	46.0 (1 167)	48.7 (1 237)	34.3 (871)	12.3 (312)	752 (341)
HD 6.0 x 36	36 (900)	6,093,000 (688 500)	70,047,000 (7 915 285)	202,250 (900 000)	625 (2 750)	93.7 (2 379)	52.0 (1 320)	54.7 (1 390)	40.4 (1 024)	12.3 (312)	822 (373)
HD 6.0 X 42	42 (1 050)	7,106,000 (803 000)	78,113,000 (8 826 743)	202,250 (900 000)	625 (2 750)	105.6 (2 683)	58.0 (1 472)	60.7 (1 542)	46.3 (1 176)	12.3 (312)	893 (405)
HD 6.0 x 48	48 (1 200)	8,000,000 (898 200)	86,232,000 (9 744 196)	178,000 (790 000)	625 (2 750)	117.7 (2 989)	64.0 (1 625)	66.7 (1 695)	52.4 (1 329)	12.3 (312)	966 (438)

Notes: 1. HD shock absorbers will function satisfactorily at 5% of their maximum rated energy per cycle.

HDA models will function satisfactorily at 10% of their maximum rated energy per cycle. If less than these values, a smaller model should be specified.

2. It is recommended that the customer consult ITT Enidine Inc. for safety-related overhead crane applications.

3. The energy data listed is for ideal linear impacts only. If side load conditions exist in the application, contact ITT Enidine Inc. for sizing assistance.

4. Rear flange mounting of 12 inch (300 mm) strokes and longer not recommended. Front and rear flange or foot mount configurations are recommended.

5. HDA models which have an impact velocity below 30 in./sec (.8 m/sec.), please contact ITT Enidine Inc. for sizing assistance.

6. Maximum cycle rate is 60 cycles/hr.

7. For impact velocities over 180 in./sec. (4.5 m/s), consult factory.

Heavy Duty Series Shock Absorber

Mounting and Accessories for HDN, HD, HDA Series

Mounting and Accessories

Typical mounting methods are shown below. Special mounting requirements can be accommodated upon request.



TM: Rear Flange Front Foot Mount



FM: Front and Rear Foot Mount
Also shown is optional safety cable, typically used in overhead applications.



TF: Front and Rear Flanges

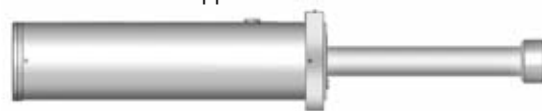

FF: Front Flange

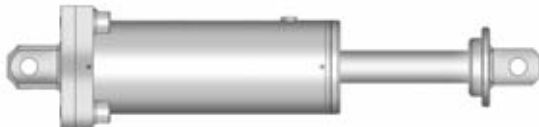

CM: Clevis Mount



FR: Rear Flange

Note: Rear flange mounting not recommended for stroke lengths above 12 inches. (300 mm)

HD(A) 3.0 x 2 → HD(A) 4.0 x 10 Series

Clevis Mounts (CM)

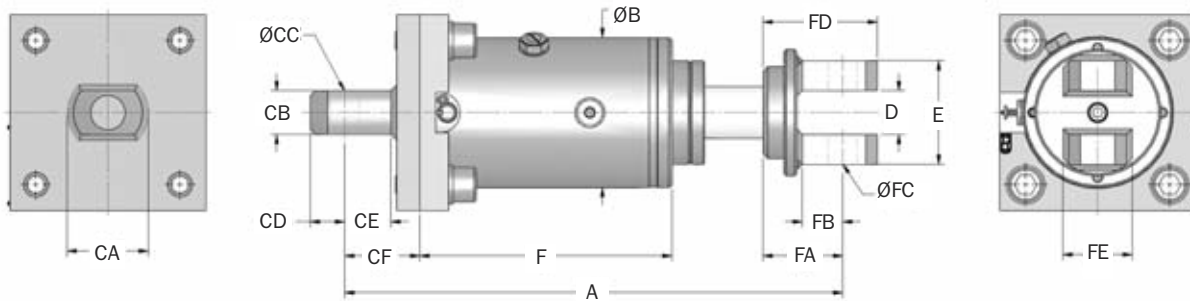

Dimensions are in inches (millimeters).

Note: Piston clevis dimensions are typical both ends on HD(A) 4.0 models.

Catalog No./ Model	HD/HDN						Cylinder Clevis Dimensions						Piston Clevis Dimensions				
	A in. (mm)	B in. (mm)	D in. (mm)	E in. (mm)	F in. (mm)	HDA F in. (mm)	CA in. (mm)	CB in. (mm)	CC in. (mm)	CD in. (mm)	CE in. (mm)	CF in. (mm)	FA in. (mm)	FB in. (mm)	FC in. (mm)	FD in. (mm)	FE in. (mm)
HD(A) 3.0 x 2	17.0 (432)	5.1 (130)	1.5 (38)	3.5 (90)	8.0 (202)	9.3 (235)	2.4 (60)	1.5 (38)	1.0 (25)	1.2 (30)	1.5 (37)	2.6 (65)	2.7 (69)	1.3 (32)	1.0 (25)	3.9 (99)	2.0 (50)
HD(A) 3.0 x 3	19.0 (483)	5.1 (130)	1.5 (38)	3.5 (90)	9.0 (229)	10.3 (261)	2.4 (60)	1.5 (38)	1.0 (25)	1.2 (30)	1.5 (37)	2.6 (65)	2.7 (69)	1.3 (32)	1.0 (25)	3.9 (99)	2.0 (50)
HD(A) 3.0 x 5	23.0 (585)	5.1 (130)	1.5 (38)	3.5 (90)	11.0 (280)	12.3 (312)	2.4 (60)	1.5 (38)	1.0 (25)	1.2 (30)	1.5 (37)	2.6 (65)	2.7 (69)	1.3 (32)	1.0 (25)	3.9 (99)	2.0 (50)
HD(A) 3.0 x 8	29.0 (736)	5.1 (130)	1.5 (38)	3.5 (90)	14.0 (355)	15.2 (387)	2.4 (60)	1.5 (38)	1.0 (25)	1.2 (30)	1.5 (37)	2.6 (65)	2.7 (69)	1.3 (32)	1.0 (25)	3.9 (99)	2.0 (50)
HD(A) 3.0 x 10	33.0 (838)	5.1 (130)	1.5 (38)	3.5 (90)	16.0 (406)	17.2 (438)	2.4 (60)	1.5 (38)	1.0 (25)	1.2 (30)	1.5 (37)	2.6 (65)	2.7 (69)	1.3 (32)	1.0 (25)	3.9 (99)	2.0 (50)
HD(A) 3.0 x 12	37.0 (940)	5.1 (130)	1.5 (38)	3.5 (90)	18.0 (457)	19.3 (489)	2.4 (60)	1.5 (38)	1.0 (25)	1.2 (30)	1.5 (37)	2.6 (65)	2.7 (69)	1.3 (32)	1.0 (25)	3.9 (99)	2.0 (50)
HD(A) 4.0 x 2	22.4 (570)	7.9 (200)	2.6 (65)	5.5 (140)	11.6 (294)	12.0 (304)	-	-	-	-	-	3.5 (90)	3.9 (100)	2.4 (60)	2.0 (50)	5.9 (150)	3.9 (100)
HD(A) 4.0 x 4	26.4 (672)	7.9 (200)	2.6 (65)	5.5 (140)	13.6 (345)	14.0 (355)	-	-	-	-	-	3.5 (90)	3.9 (100)	2.4 (60)	2.0 (50)	5.9 (150)	3.9 (100)
HD(A) 4.0 x 6	30.4 (772)	7.9 (200)	2.6 (65)	5.5 (140)	15.6 (395)	15.9 (405)	-	-	-	-	-	3.5 (90)	3.9 (100)	2.4 (60)	2.0 (50)	5.9 (150)	3.9 (100)
HD(A) 4.0 x 8	34.4 (875)	7.9 (200)	2.6 (65)	5.5 (140)	17.6 (477)	18.0 (457)	-	-	-	-	-	3.5 (90)	3.9 (100)	2.4 (60)	2.0 (50)	5.9 (150)	3.9 (100)
HD(A) 4.0 x 10	38.4 (976)	7.9 (200)	2.6 (65)	5.5 (140)	19.6 (497)	20.0 (507)	-	-	-	-	-	3.5 (90)	3.9 (100)	2.4 (60)	2.0 (50)	5.9 (150)	3.9 (100)

Optional Piston Rod Return Sensor

- Magnetic proximity sensor indicates complete piston rod return with 10-foot (3 m) long cable.
- If complete piston rod does not return the circuit remains open. This can be used to trigger a system shut-off.
- Contact ITT Enidine Inc. for other available sensor types.
- Sensor port in line with charge port on models HDN 1.5, 2.0 and 4.0. Location offset 90° for models HDN 3.0 and 3.5.

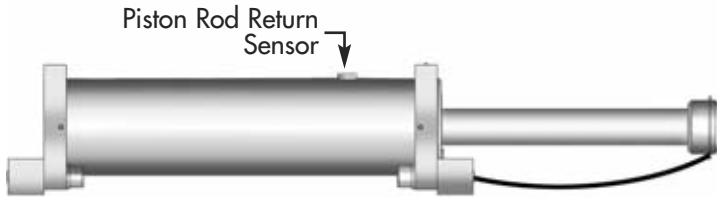

Sensor Specifications

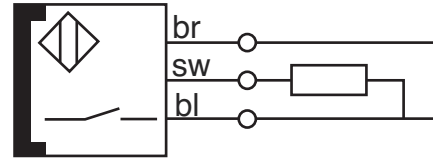

- Voltage 10 - 30V
- Load Current ≤ 200 mA
- Leakage Current ≤ 80 mA
- Load Capacitance ≤ 1.0 mF
- Ambient Temperature: -15° to 160°F (-26° to 71°C)

Urethane Cap

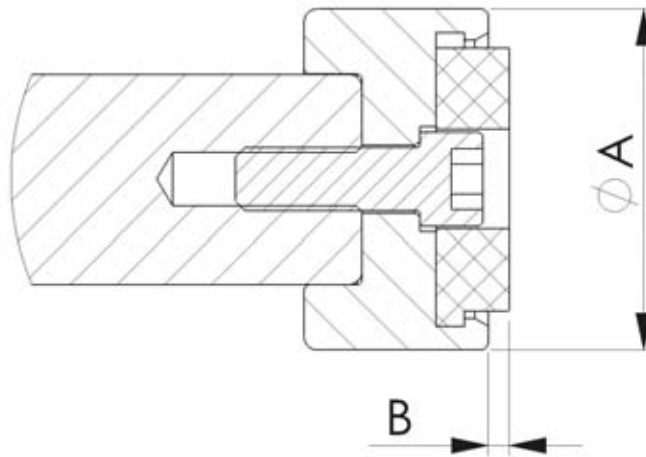

Model	Dia. A (mm)	Dia A (in.)	B (mm)	B (in.)
HDN 1.5	60	2.36	4	0.16
HDN 2.0	65	2.56	4	0.16
HDN 3.0	70	2.76	4	0.16

HEAVY DUTY SHOCK ABSORBERS

Applications:

- Control of bridge cranes
- Trolley platforms
- Large container transfer
- Automated aisle stacker cranes
- Cab operated bridge cranes
- Ship to shore container cranes
- Overhead bridge cranes
- Gantry cranes
- Ship to shore container cranes
- Transportation end stops





ENGINEERED FOR LIFE

ITT Enidine Inc.
7 Centre Drive
Orchard Park, New York 14127
USA
Phone: 716-662-1900
Fax: 716-662-1909
Email: industrialsales@enidine.com
www.enidine.com

ITT Control Technologies GmbH
Werkstrasse 5
D-64732, Bad Koenig, Germany
Phone: +49 6063 9314 0
Fax: +49 6063 9314 44
Email: info@enidine.eu
www.enidine.eu